

Opal Matte Black 400ml Liquid Spray Soap Dispenser

Opal[®]
Range



Part Number 400SD-SBK

UK Manufactured in zinc coated steel
High quality, durable refillable soap dispenser
400ml capacity, with removable spray pump reservoir
Contemporary matte black finish - RAL 9005
Resist of fingerprints, simple to clean and maintain
Front window to check stock levels
Key lockable with low profile chrome lock
Fixing kit and key provided

The Opal Range is an official Made In Britain product

Height 202mm
Width 95mm
Projection 98mm



Dimensions

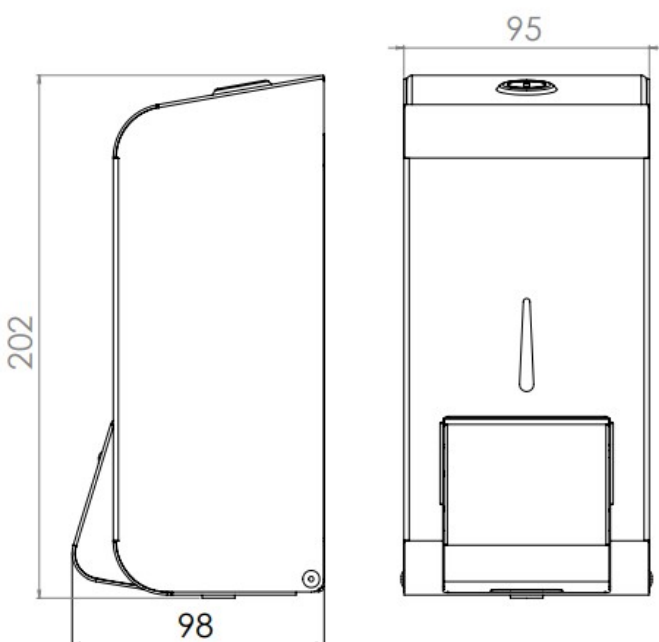

Suitability

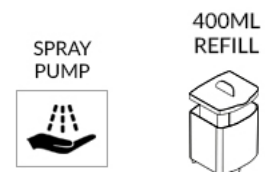

Liquid sanitiser
Pump standard (0.5ml Shot) – Spray action

Available Spare Parts

4RM-M Reservoir, **4MP-S** Pump, **5099** lock + key

Note The Opal spray soap dispenser is designed for conversion. Additional foam or liquid pumps are also available. **Part No 4M-F- / 4MP-L**